



**DRIVER:** Steve Salvas  
**DATE:** October 26th, 2012  
**EVENT:** USOW 2012  
**CLASS:** Mod Sprint  
**TRACK:** Bumps & Jumps **LENGTH:** 145'  
 Clay  Hard Packed  Loose Dirt  
 Carpet  Asphalt  Concrete  
 Flat  Banked  True Oval  Tri-Oval  
**Traction:**  High  Medium  Low

**RIGHT FRONT SUSPENSION LEFT**

CAMBER: -1.5 TOE IN/OUT AMOUNT: zero RF  LEAD  TRAIL CAMBER: 0  
 CAMBER LINK LOCATION SHOCK POSITION:  TOP  MID  BOT CAMBER LINK LOCATION  
 OUTER  INNER CAMBER RATE SHIMS: none CAMBER RATE SHIMS: none  
 KINGPIN INCLINE  0°  ANGLED KINGPIN INCLINE  0°  ANGLED



ACKERMANN:  ON SPINDLE  SHORT  MIDDLE  LONG  
 SUSPENSION POSITION RF:  OUTER  MIDDLE  INNER LF:  OUTER  MIDDLE  INNER  
 ACKERMANN:  ON SPINDLE  SHORT  MIDDLE  LONG

FRONT AXLE:  STOCK  EXTENDED CASTOR:  0°  +5°  -5°  -10° KICK-UP:  25°  20° HIGH  20° LO  15° HIGH  15° LO CASTOR:  0°  +5°  -5°  -10° FRONT AXLE:  STOCK  EXTENDED  
 AXLE SHIMS: none SWAY BAR:  NONE  .063"  .078" AXLE SHIMS: none

**LEFT REAR SUSPENSION RIGHT**

CAMBER LINK LOCATION  OUTER  INNER CAMBER LINK LOCATION  INNER  OUTER  
 HUB SPACING: SHADE IN 4 SPACERS  1  2  3  4  5  6  7  8  9  10 HUB SPACING: SHADE IN 4 SPACERS  1  2  3  4  5  6  7  8  9  10  
 CAMBER: +2 CAMBER: -1.5  
 TOE-IN: 2 in TOE-IN: 2 out  
 WHEEL SPACERS: None WHEEL SPACERS: .125"

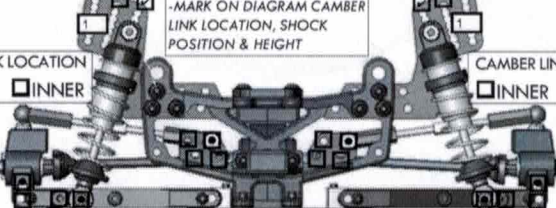

SWAY BAR:  NONE  .063"  .078" REAR WIDTH (INNER/OUTER) LR: Inner RR: Middle  
 TOE-BLOCK SHIMS: LR: High Chair RR: High Chair  
 ANTI-SQUAT SHIMS: LR: none RR: none

**TIRES & TRACTION**

TIRE TYPE:  FOAM  STREET RUBBER  LOOSE DIRT  
 COMPOUND DIAMETER INSERT  
 RF: BSR Orange 2.55 (5) | (5) |  
 LF: BSR 25 2.58 LF RF  
 RR: BSR Orange 2.55 (5) + (5) +  
 LR: BSR Orange 2.56 LR RR

TRACTION ADDITIVE: Magic IT / Paragon (50%-50%)  
 Brown track : Full RF (3 - BSR Orange / RF - BSR 25)  
 Black track : 1/2 RF and 1/2 LF (4 - BSR 25)

**SHOCKS**

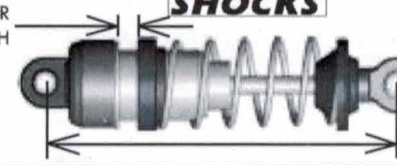

**LEFT FRONT SHOCK**

BODY LENGTH  SHORT  MED  LONG  
 SHAFT LENGTH  SHORT  MED  LONG  
 SPRING: Blue 17lbs (CW#1443)  
 OIL: 35 Losi PISTON: M  
 BLADDER: Black  
 LENGTH: Full (adj. droop screw)  
 COLLAR: 0.330"

**RIGHT FRONT SHOCK**

BODY LENGTH  SHORT  MED  LONG  
 SHAFT LENGTH  SHORT  MED  LONG  
 SPRING: Blue 17lbs (CW#1443)  
 OIL: 35 Losi PISTON: M  
 BLADDER: Black  
 LENGTH: Full (adj. droop screw)  
 COLLAR: 0.350"

**LEFT REAR SHOCK**

BODY LENGTH  SHORT  MED  LONG  
 SHAFT LENGTH  SHORT  MED  LONG  
 SPRING: Silver 8lbs (CW#1488)  
 OIL: 35 Losi PISTON: M  
 BLADDER: Black  
 LENGTH: 60.0mm  
 COLLAR: 0.165"

**RIGHT REAR SHOCK**

BODY LENGTH  SHORT  MED  LONG  
 SHAFT LENGTH  SHORT  MED  LONG  
 SPRING: Silver 8lbs (CW#1488)  
 OIL: 35 Losi PISTON: M  
 BLADDER: Black  
 LENGTH: 60.0mm  
 COLLAR: 0.050"

**WEIGHT & CHASSIS HEIGHTS**

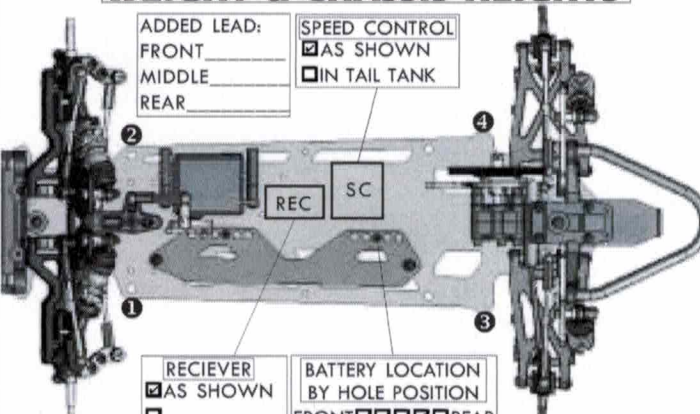

ADDED LEAD: FRONT \_\_\_\_\_ MIDDLE \_\_\_\_\_ REAR \_\_\_\_\_  
 SPEED CONTROL:  AS SHOWN  IN TAIL TANK  
 RECIEVER:  AS SHOWN  \_\_\_\_\_  
 BATTERY LOCATION BY HOLE POSITION: FRONT     REAR

CORNER WEIGHTS:  
 LF: 322 RF: 318  
 LR: 467 RR: 442  
 OVERALL WEIGHT: 54.7oz

CHASSIS HEIGHTS BY LOCATION:  
 1 9.0mm 2 9.0mm  
 3 10.0mm 4 10.0mm  
 MEASURED FROM:  
 TOP OF CHASSIS  
 BOTTOM OF CHASSIS

**WING**

MAIN WING SIZE:  6X6  7X7  
 FRONT WING SIZE: DODC  
 SPOILER LENGTH: DODC  
 WING LOCATION:  
 LOW WING  HIGH WING   
 HOOD TYPE:

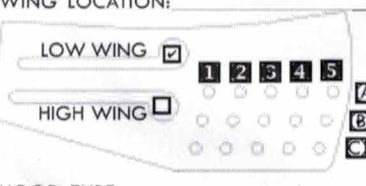

**MISC...**

MOTOR: Tekin Redline 6.5 Gen2  
 PINION: 1.10" RO SPUR:  
 SPEED CONTROL: Tekin RS-Pro  
 PUNCH SETTING: 44 Boost  
 INTIAL BRAKE: 1'500-29'000RPM  
 AUTO BRAKE:  
 Amp Draw: ... (free rev no pinion)  
 ... 30A (adj via Motor Timing)

Rear shock ears are the smaller graphite versions (Top hole - most inside)  
 Front Droop : + 2.5mm (adjusted with droop screws ... cage on)  
 Rear Droop : + 6.0mm (adjusted with shock length ... cage on)